

- **Input Voltage 24 ~70VDC**
- **Over-Voltage Protection 90V**
- **Under-Voltage Protection 15V**
- **Cooling Method (Natural Air Cooling)**
- **Operating Temperature -0°C ~ 40°C**
- **Operating Humidity 85% RH (Non-Condensing or Water Drops)**
- **Weight 0.36Kg**
- **Ingress Protection IP20**
- **RS785 or CAN Bus Interface**

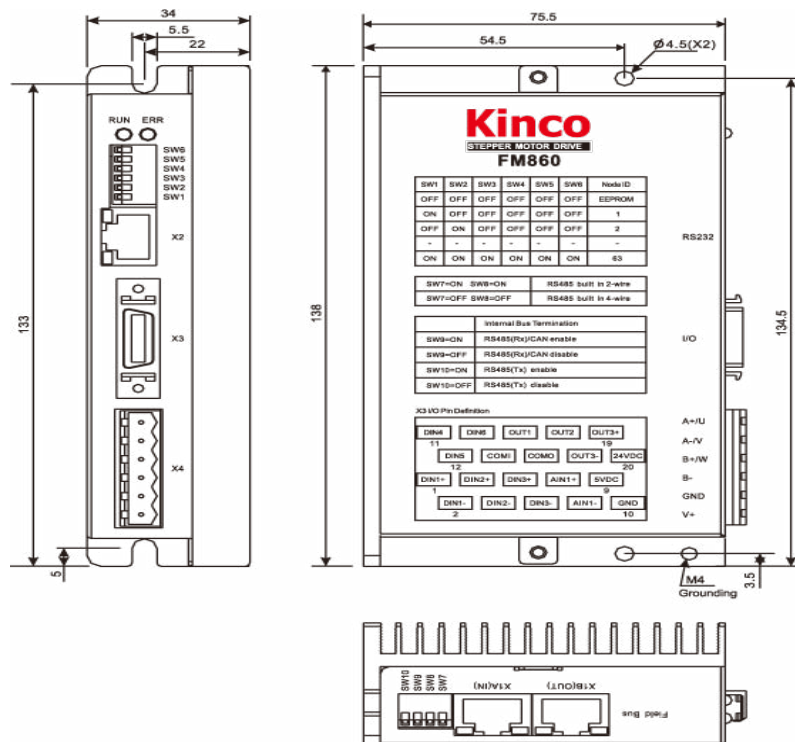

The FM860 Series Stepper Driver provides improved dynamic drive performance. This series drive accepts 24~70VDC input, with up to 6 Amps per phase, and provides users the ability to set up the step resolution set by KincoStep Software. As an additional feature, this drive provides users with the ability to select an auto reduce current setting which helps reduce power consumption and motor heat, while improving motor lifetime. Also, the isolation inputs help minimize interference from external electrical equipment as well as improving performance.



(Units Are In mm)

Technical Specifications	
Input Voltage	24 to 70VDC
Over-Voltage Protection	90V
Under-Voltage Protection	15V
Phase Current (Peak)	0 to 6A
Subdivision	Set by "KincoStep" Software
Adaptable Motor	56/86 Series Two-Phase or 57/85 Series Three-Phase Hybrid Stepper Motor
Control Signal Mode	PLS+DIR, CW/CCW, A+B
Cooling Method	Natural Air Cooling
Operation Environment	Avoid the Environment With a Great Amount of Metallic Powder, Oil mist, or Errosive Gases
Operation Humidity	<85%, RH(Non-Condensing or Water Drops)
Operation Temperature	0°C to +40°C
Storage Temperature	-20°C to +70°C
Weight	0.36Kg
Dimensions	134.5x75.5x34mm
Ingress Protection	IP20

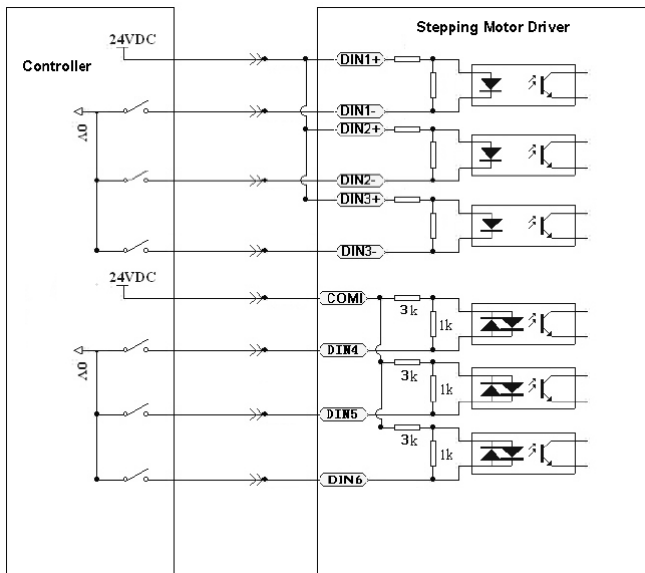

NPN Wiring Diagram

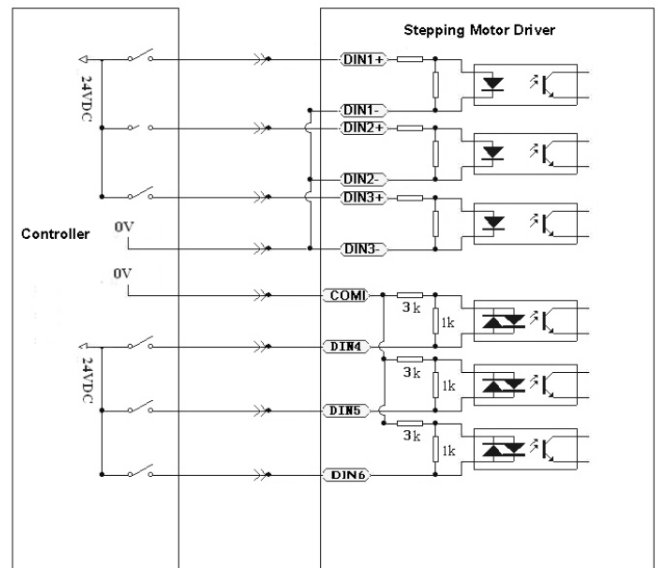

PNP Wiring Diagram

Interface	Symbol		Function
X1 (Field Bus)	SW7 to SW8	Switches for Setting 2-Wire or 4-Wire RS485	Switches for Communication Interface Setting
	SW9 to SW10	Switches for Terminal Resistor Setting	
	X1A(IN)X1B(OUT)		CAN bus or RS485 Interface
ID DIP	SW1 to SW6		ID Rotary Switch
X2	RS232		RS232 Interface
X3 (IO)	DIN1+	DIN1 Positive	High Speed Digital Input Interface Input Voltage: 3.3 to 24VDC Valid Input Signal: >2.5VDC and >4mA Invalid Input Signal <1.5VDC Maximum Input Frequency of Optocoupler: 1MHz
	DIN1-	DIN1 Negative	
	DIN2+	DIN2 Positive	
	DIN2-	DIN2 Negative	
	DIN3+	DIN3 Positive	
	DIN3-	DIN3 Negative	
	DIN4	DIN4 Input	Low Speed Digital Signal Input Interface Scope of Input Voltage: 12 to 24VDC Valid Input Signal:>8VDC and >3mA Invalid Input Signal: <5VDC Max. Input Frequency of Optocoupler: 10kHz
	DIN5	DIN5 Input	
	DIN6	DIN6 Input	
	COM1	Common Port of DIN4,DIN5,DIN6	
	AIN1+	AIN1 Differential Signal Positive	The Analog Signal Input Interface The Input Impedance: 180K Max. Input Frequency: 4kHz Max. Withstand Voltage: 24VDC
	AIN-	AIN1 Differential Signal Negative	
	GND	Common Port of AIN1 and Logic Power Supply	
	5VDC	5VDC Logic Power Output	The Maximum Output Current: 200mA
	24VDC	24VDC Logic Power Input	Auxillary Logic Power Supply when External Power Supply Does not Work
	OUT1	OUT1 Output	Max. Ouput Current: 100mA Max. Withstand Voltage: 24VDC Max. Output Frequency of Optocoupler: 1kHz
OUT2	OUT2 Output		
COMO	Common Port of OUT1 and OUT2		
OUT3+	OUT3 Positive		
OUT3-	OUT3 Negative		